

# X·Ar

## Quick Start Guide

---

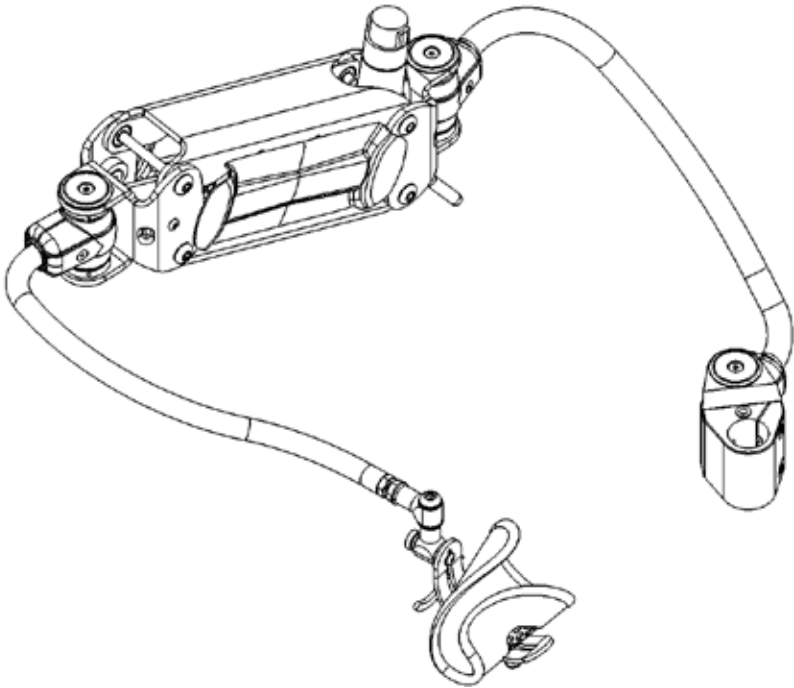

X-Ar Arm

---

Equipois Inc.  
5440 McConnell Avenue  
Los Angeles, CA 90066  
(310) 736-4130

equipois®  
DEFY GRAVITY®

info@equipoisinc.com | www.equipoisinc.com

# Table of Contents

Box Contents X-Ar Arm.....	1
Cuff Right Hand/Left Hand Reference .....	2
Cuff Size Reference .....	3
Cuff Size Change Instructions .....	4
Cuff Assembly to X-Ar Arm .....	6
Assembly of X-Ar to Chair Mount .....	7
X-Ar Arm Assembly to Workstation Mount .....	8
Lift Adjustment .....	10
Cuff Docking Kit .....	11

---

## Read Me!

NOTE: If your X-Ar Arm came with a mounting accessory, please set-up the mounting accessory before setting up your X-Ar Arm.

### Tools required for assembly:

- 6 mm Allen wrench for X-Ar Arm assembly to mount (included in mount parts kit)
- 9/64 Allen wrench for cuff assembly to arm (included)
- Flat blade screw driver for cuff size change (not included)



9/64 allen  
wrench  
(included)



6mm allen  
wrench  
(included with  
mount kits)



flat blade  
screwdriver

# Box Contents X-Ar Arm

*Note: Check box contents to verify delivery of all X-Ar system parts*

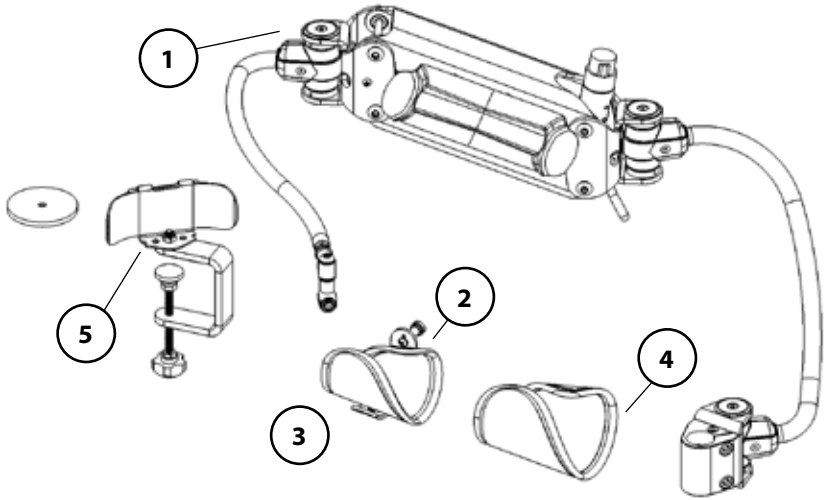

1. X-Ar arm
2. X-Ar cuff assembly
3. (sm/med cuff size installed)
4. X-Ar med/large size cuff
5. Docking kit

# Cuff Right/Left Hand Reference

*Note: The geometry of right and left handed cuffs and corresponding covers*

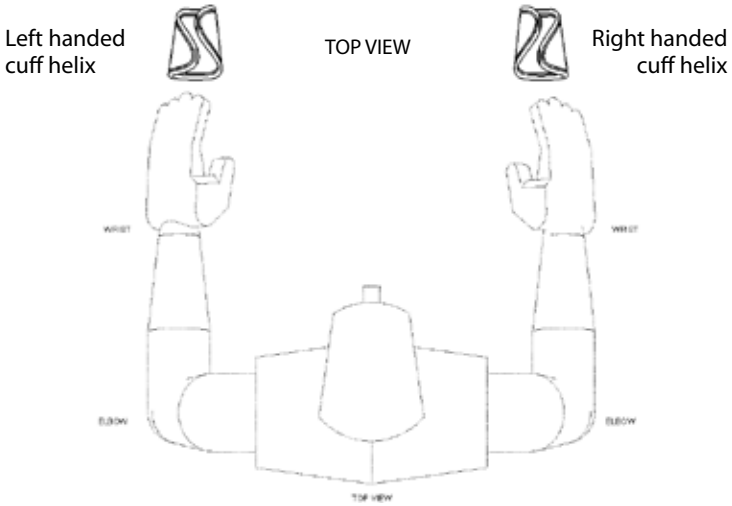
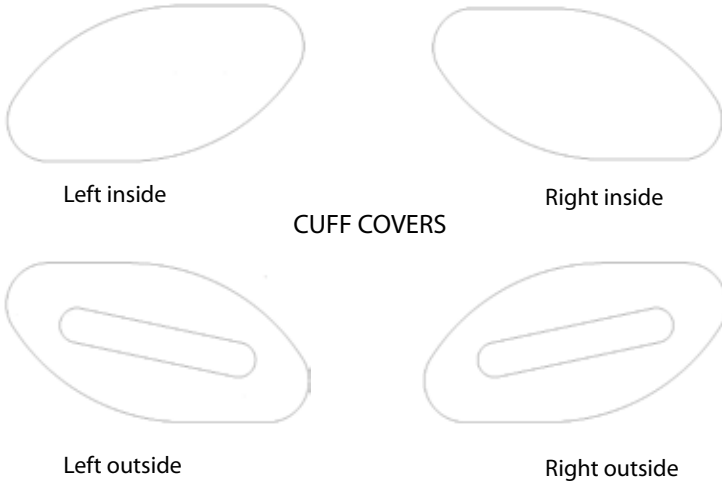

# Cuff Size Reference

Note: Cuff fit should be snug but not uncomfortable. Use hands to expand or contract cuff helix for better fit.

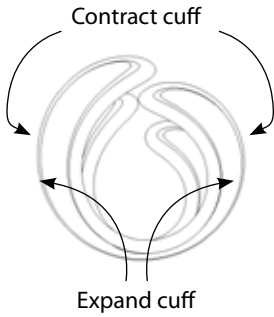

Small arm circumference = 5" - 11"  
 Large arm circumference = 9" - 14"

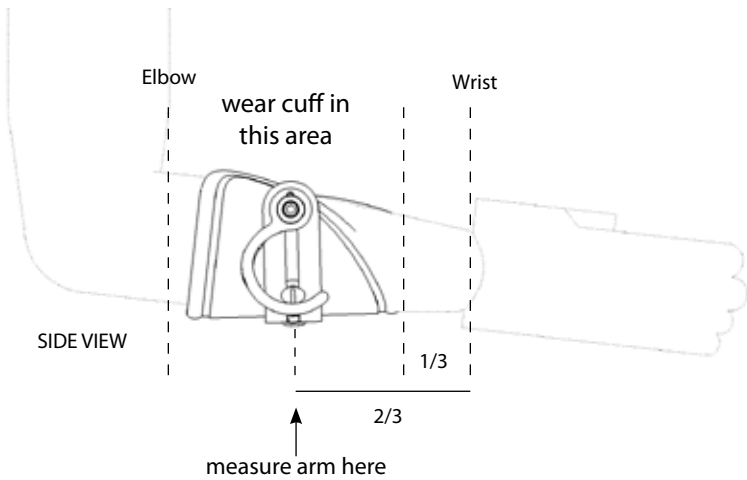

## ARM CIRCUMFERENCES

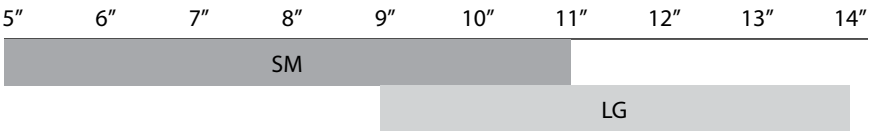

# Cuff Size Change Instructions

## Step 1 - Remove cuff cover

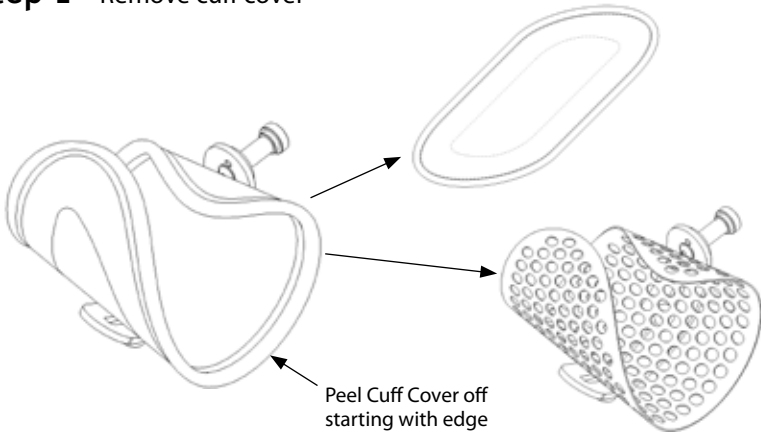

## Step 2 - Remove cuff hardware with flat head screw driver

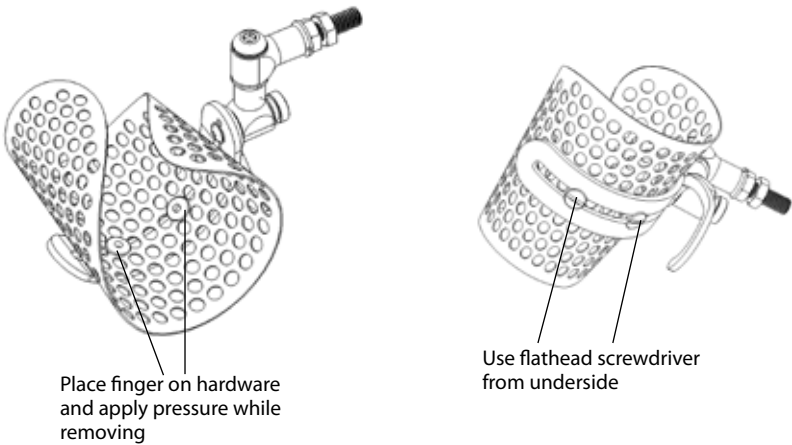

**Step 3** - Replace cuff helix with alternate size. Used marked holes.  
Position as shown.

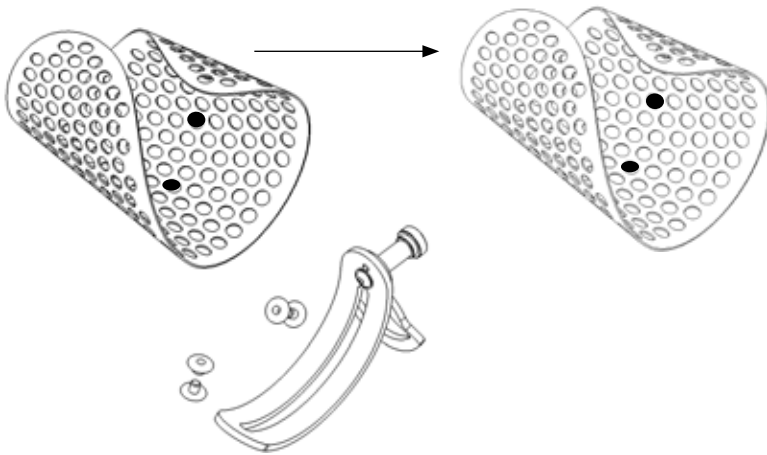

**Step 4** - Reassemble cuff hardware.

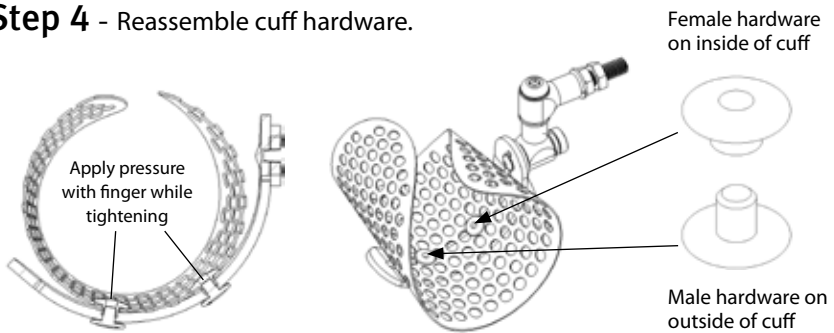

**Step 5** - Assemble cuff cover over cuff helix as shown.

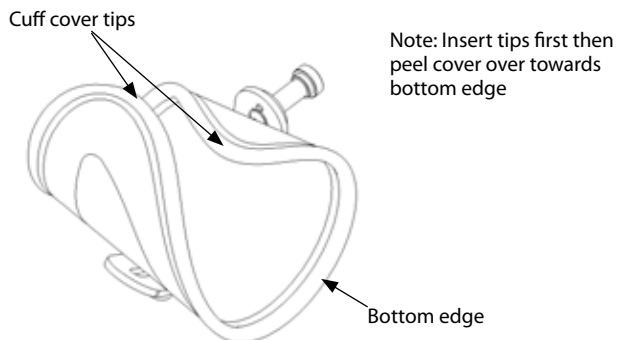

# Cuff Assembly to X-Ar Arm

*Note: Use 9/64 allen wrench (included) to remove and replace cuff screw.*

1. Remove cuff screw
2. Place cuff axle through wrist joint
3. Replace and retighten cuff screw

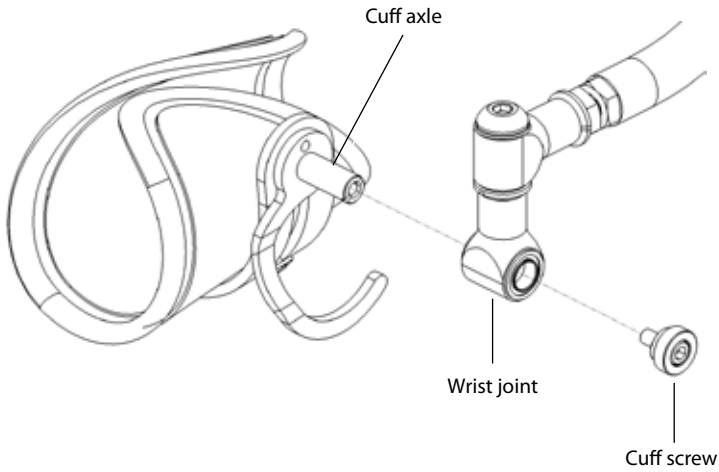

# Assembly of X-Ar to Chair Mount

*Note: Lift knob and bubble level are on top side of X-AR arm.*

1. Place arm mount clamp onto vertical post.
2. Bubble level on arm mount clamp can be used to fine tune level of vertical post
3. Note orientation of Back joint and chair in "Top view"
4. Secure screws tightly once properly positioned

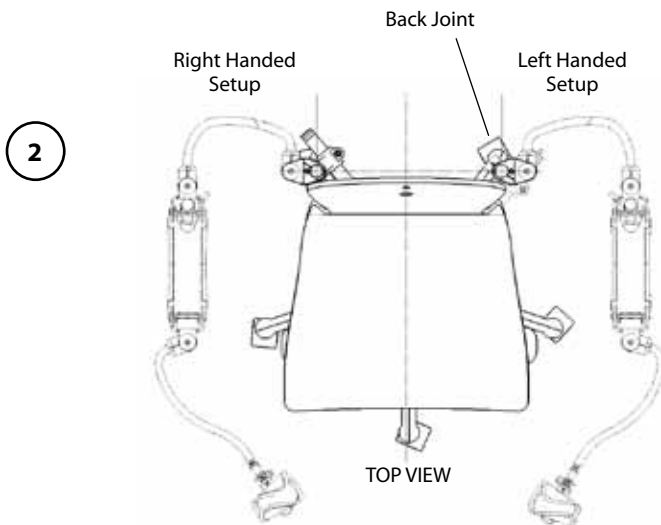
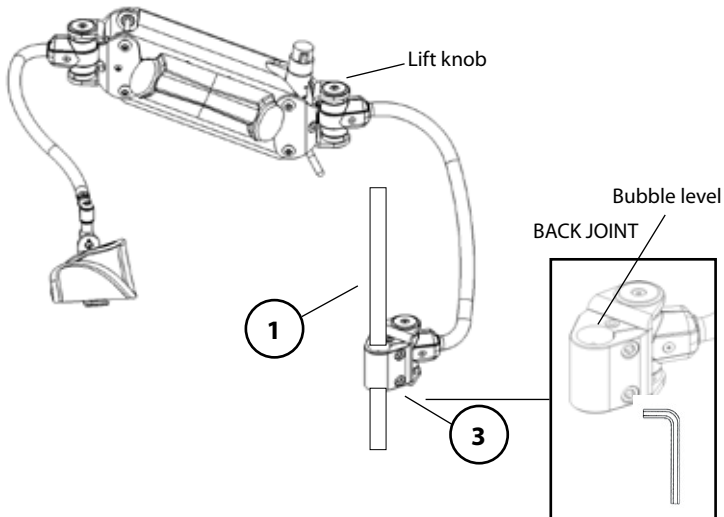

# Assembly of X-Ar to Workstation Mount

- Place arm mount clamp onto vertical post
- Bubble level on arm mount clamp can be used to fine tune level of vertical post
- Adjust arm mount clamp angle and height as shown on next page

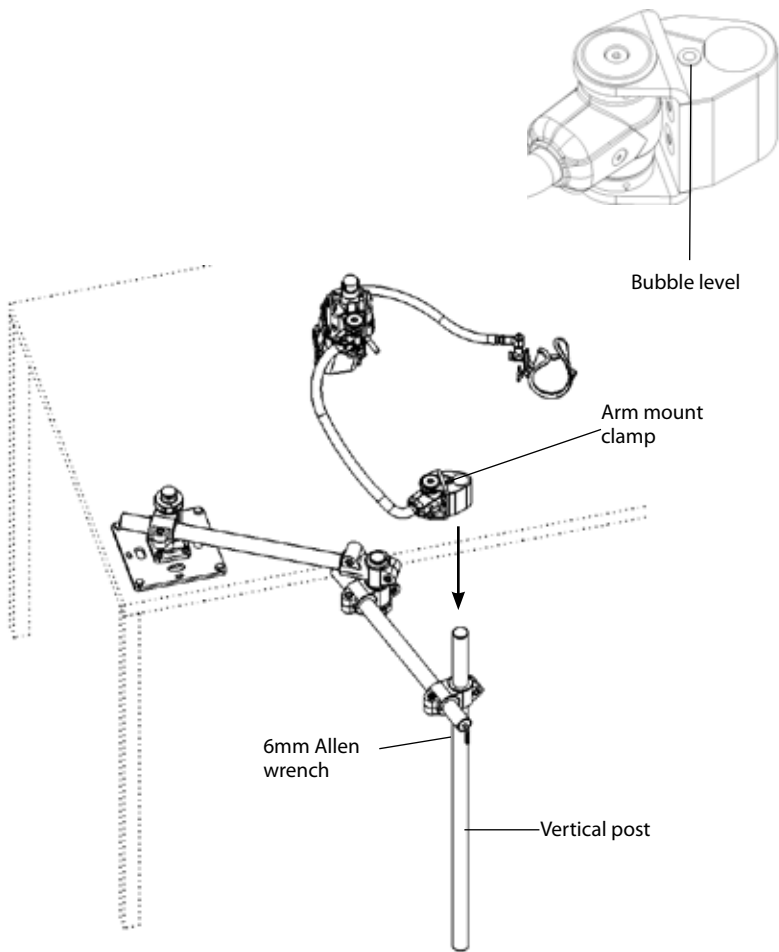

# Continued...

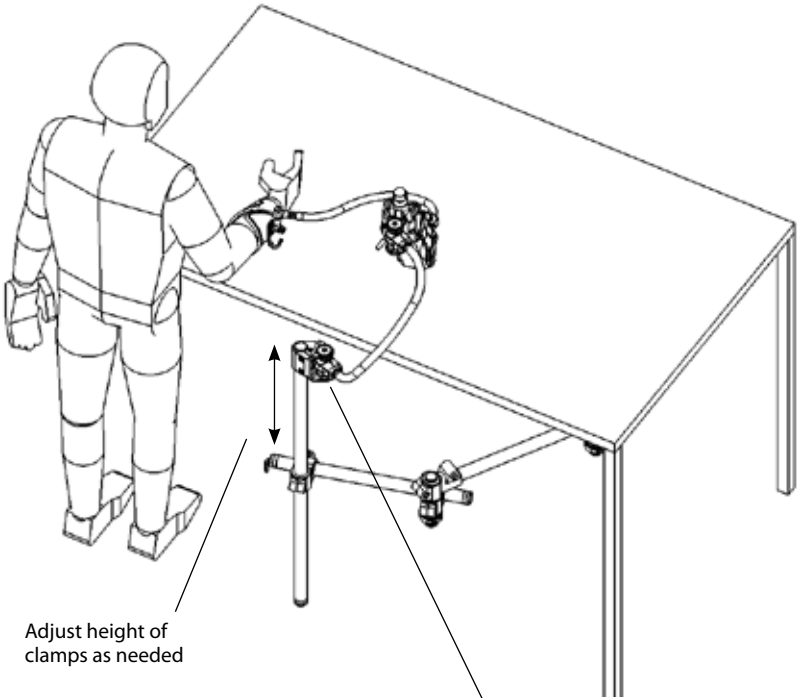

Adjust height of clamps as needed

Adjust Arm clamp angle as needed

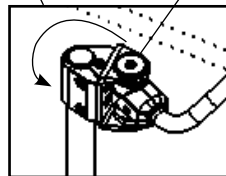

# Lift Adjustment

- Shoulder muscles should feel relaxed when X-Ar lift is adjusted to properly to balance weight of forearm and tool.
- "Floating feeling" occurs in arm when lift knob has been properly adjusted for arm weight, arm should neither rise nor fall.
- Height of X-Ar arm mount clamp should be adjusted to keep relaxed forearm in middle of lift travel.

Lift knob

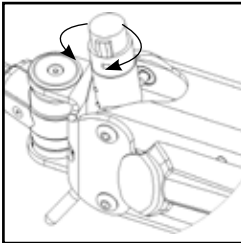

- *Adjust knob clockwise for added lift.*
- *Counterclockwise diminishes lift force.*
- *Knob tracks lift force with numerical value*

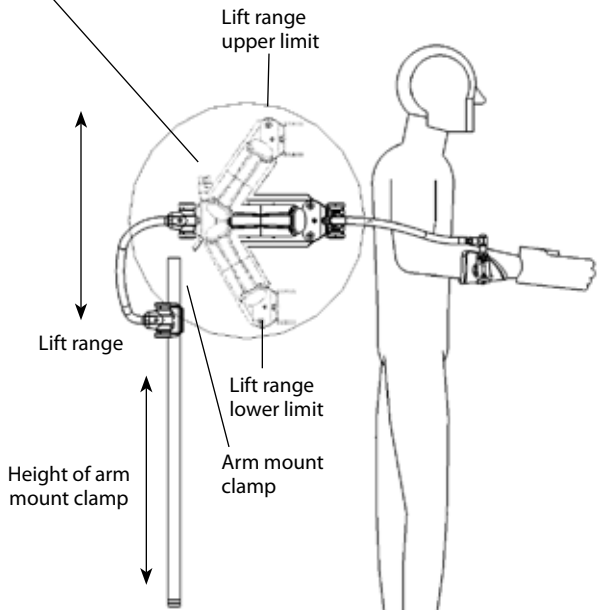

# Cuff Docking Kit

## 1. Selection of Docking Kit parts

- There are two different configurations of the cuff docking kit
  - Docking flange is pre-assembled to clamp base as shown
  - Adhesive base mount is included but not assembled

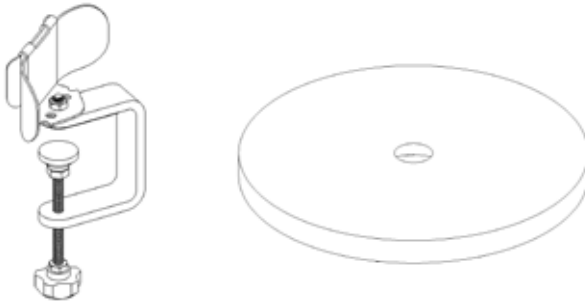

## 2. Configurations of docking kit:

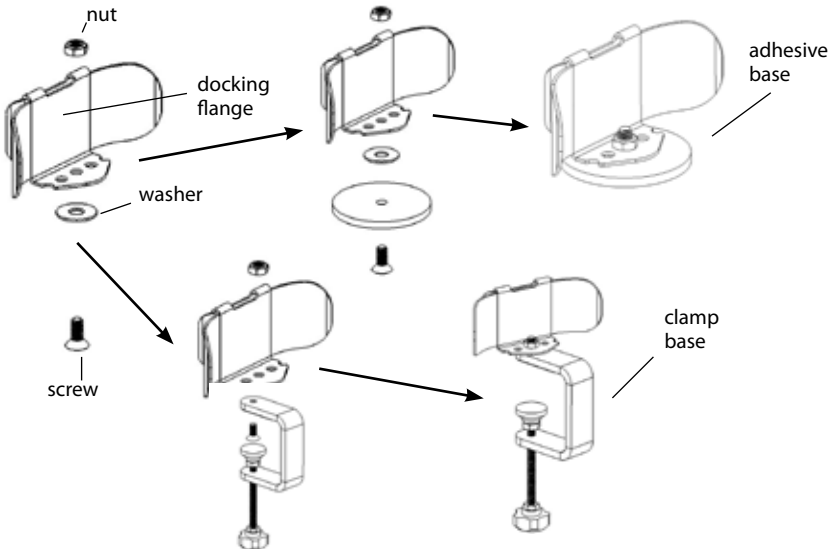

- Use washer, screw and nut to transfer docking flange from clamping style to adhesive base style.
- Tighten screw such that washer is clamped tightly between base and dock flange.
- Docking flange should still be repositionable with respect to the clamp base or adhesive base.

### 3. Placement of Docking Parts:

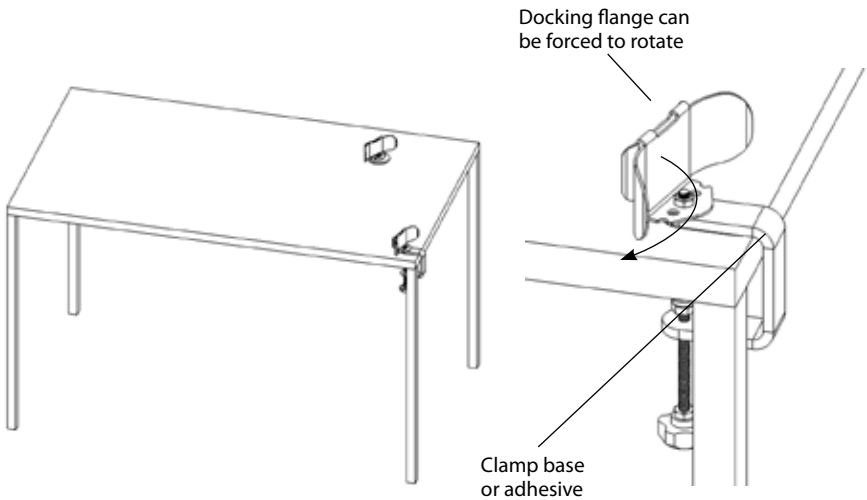

- Place dock to the right of right-handed arm cuff or left of left-handed arm cuff
- Dock should be placed near the edge of the work table so it is not an obstacle when the arm is not in use.
- Clamp mount is designed to quickly and easily mount to the edge of a workbench.
- Adhesive plate mount should be used in situations where the dock is best placed in the interior of a workbench.
- NOTE:
  - Adhesive dock mount must be used on a clean flat surface to function properly.
  - Adhesive plate mount will not properly adhere to textured, dirty or non-level surfaces.
  - Clean and dry area for dock to be placed.
  - Remove covering on PSA adhesive on bottom of docking plate and place firmly onto table.

## 4. Alignment of Cuff Dock:

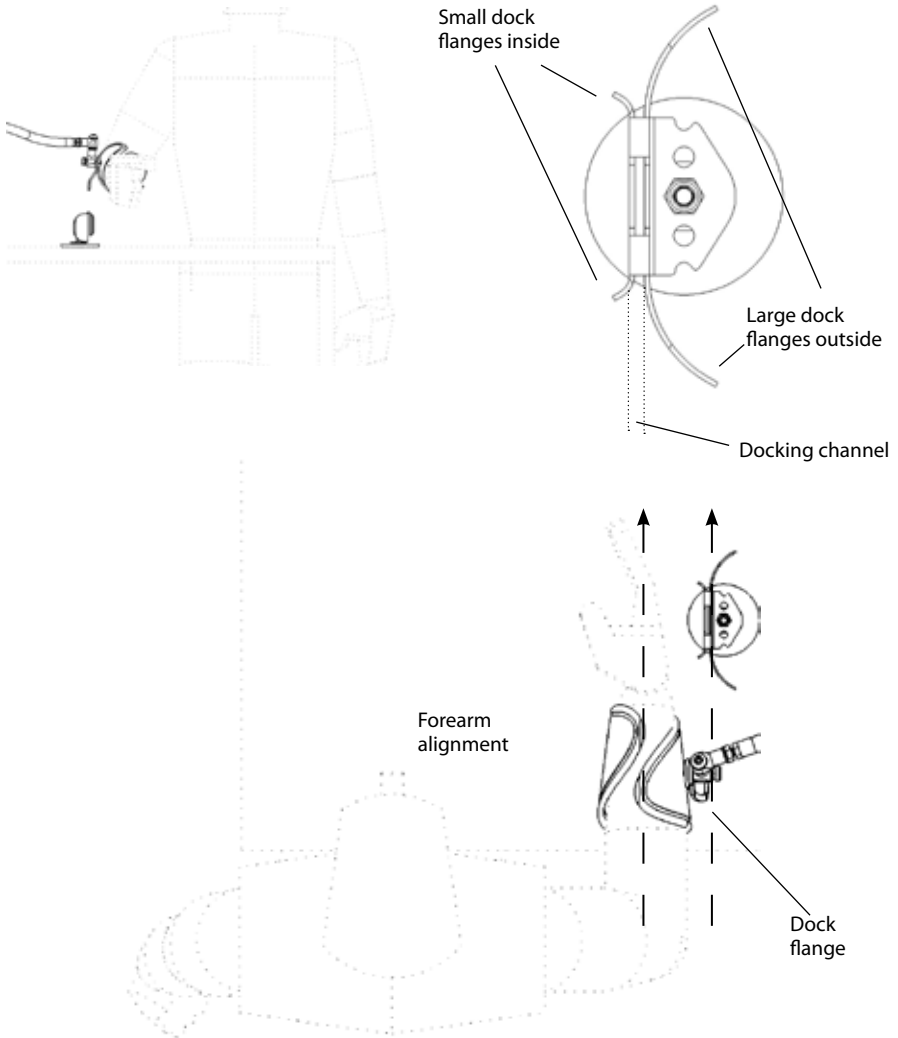

- Docking flange should be rotated to align with human forearm as shown.
- Small flanges on inside closest to the cuff should be parallel with forearm.
- Dock will work with right and left handed cuffs.
- Note that the small tabs of docking base are facing inward toward forearm.

## 5. Use of Cuff Docking:

### To engage cuff hook into docking mount:

- Align forearm with docking flange channel.
- Use a strait, then upward motion to guide the cuff hook into the dock channel.
- The upward motion secures the arm rest in the dock.

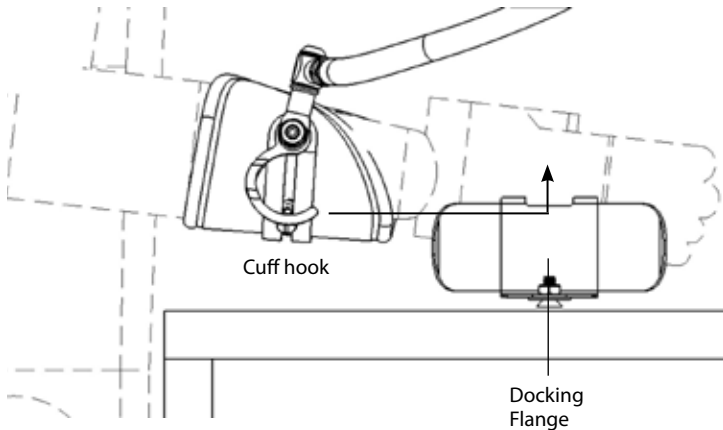

### To disengage cuff hook from docking mount:

- Thrust arm into arm rest with forward motion until arm is captured in arm rest at proper location along forearm.
- Use downward pressure to release hook from hook bracket.
- Retract arm with attached arm rest in strait motion back out of docking channel.

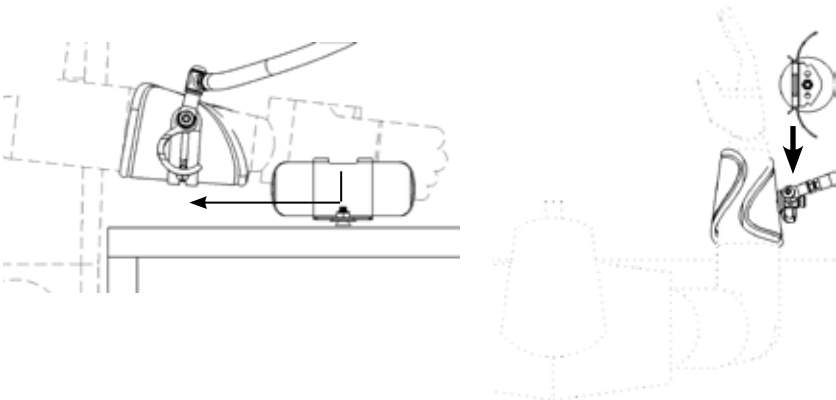

## 6. Adjust Docking Flange:

- If docking flange is difficult to enter or remove with cuff hook, expand docking channel with a flat head screw driver.
- Expand channel a small amount at a time and test fit.

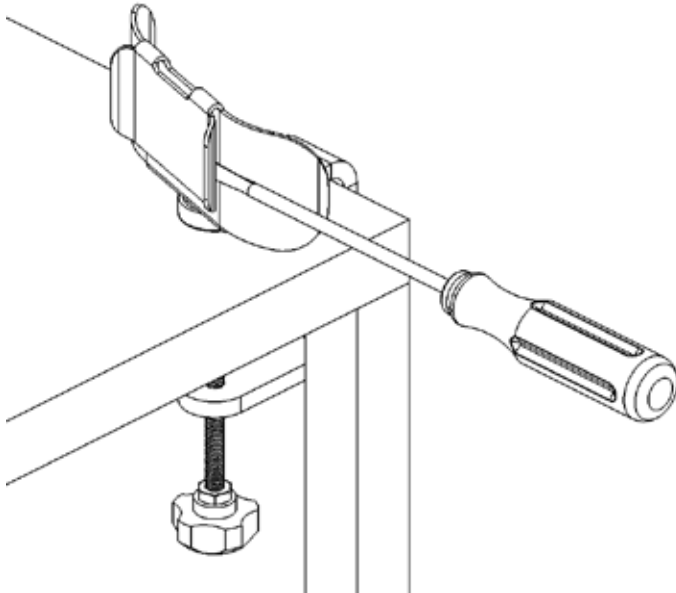
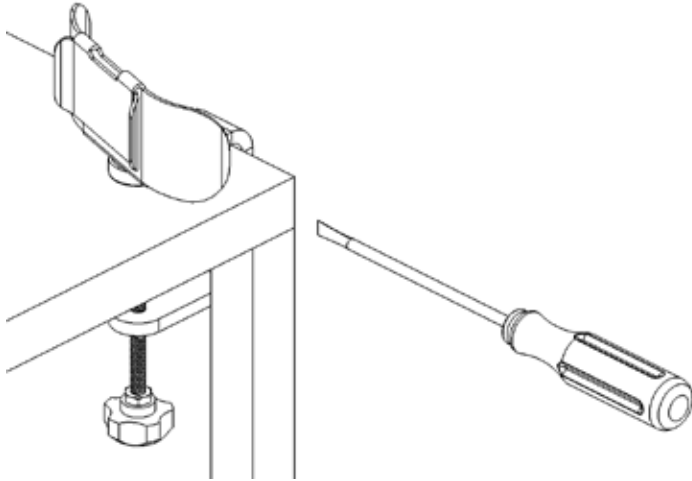

# Thank you for your X-Ar purchase

To receive X-Ar announcements, and future accessory product announcement offers, email us at **X-Ar@equipoisinc.com**.

For information about the Equipois zeroG product line, visit us online at **www.equipoisinc.com**. zeroG is mechanical arm technology that allows workers to hold tools, parts, and other payloads and operate as if weightless with unmatched freedom of motion.

For additional details about your X-Ar product including product updates, maintenance data and additional information about the X-Ar user community, please visit <http://www.equipoisinc.com/products/xAr/>.

equipois®

Equipois Inc.  
5440 McConnell Avenue  
Los Angeles, CA 90066  
(310) 736-4130

[info@equipoisinc.com](mailto:info@equipoisinc.com)  
[www.equipoisinc.com](http://www.equipoisinc.com)