

Equipois Inc.
zeroG⁴ Arm
Set-up Manual
Revision E

Equipois Inc.
5440 McConnell Avenue
Los Angeles, CA 90066

Information
310-736-4130
info@equipoisinc.com

Support
866-601-2770
support@equipoisinc.com

Contents

Glossary..... 4

Getting started6

 Unpacking..... 6

 Verify the mounting system..... 6

Attach the zeroG arm to the mounting system 10

 Attaching the mounting interface block..... 10

 Attaching the arm to the mounting interface block..... 10

 Adjusting centering..... 11

 Mounting the payload..... 12

 Docking 13

 Adjusting the lift 14

 Adjusting the rate 15

 Installing accessories 15

Adjust the gas springs 16

 Removing the gas springs..... 17

 Installing the gas springs 18

Appendices 23

 Maintenance and Upkeep..... 23

 zeroG⁴ arm technical specifications..... 32

 Safety and hazard review 32

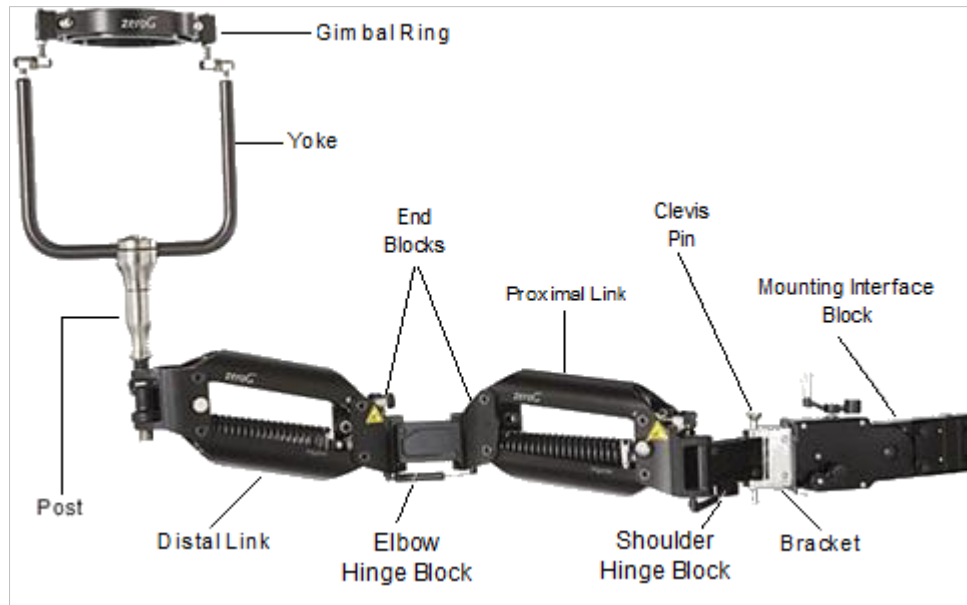

Glossary

Italicized terms in the definitions have their own glossary entries.

clevis pin—The quick-release pin that attached the shoulder *hinge block* to the *mounting interface block*.

centering—The movement of the arm to a horizontal rest position when the tool is released.

dock—A mechanism for fastening the zeroG[®] arm in a folded, out-of-the-way position.

end block—One of several pieces that connect the upper and lower assemblies of a *link* and contain the sockets for connecting the link variously to the *hinge block*, *mounting interface block*, or the *gimbal post*.

gimbal—The mechanism that holds the tool* while allowing it to rotate freely. The gimbaling mechanism includes the *yoke* and is attached to the arm, often by a *post*.

hinge block—See *link*.

iso-elasticity—The zeroG arm's property of requiring virtually the same force to move the tool* up and down over the vertical range of motion. As iso-elasticity is decreased, the range of iso-elastic motion becomes narrower, and the force required to move the tool increases more quickly as it is moved toward the top and bottom of the range. Iso-elasticity can be adjusted with the Rate knob.

lift—The upward force with which the arm supports the *payload*.

link—A segment of the arm. Installations that require minimal vertical range use one dynamic link and one static link, which has no spring and adjusters.

The arm's links are termed the "distal" or forearm link and the "proximal" or upper arm link. The shoulder hinge block connects the proximal link to the *mounting interface block*, and the elbow hinge block connects the distal link to the proximal link.

mounting interface block—The connector that is fastened to the *mounting system* and includes the socket to which the shoulder *hinge block* of the zeroG arm is attached.

*zeroG arms can support things beside tools, such as parts and assemblies. For simplicity, "tool" in this document refers to whatever the customer mounts in the gimbal.

mounting system—The structure that supports or transports the arm within range of the *work*.

payload—The assembly supported by the arm, including the *tool**-*gimbal-post* assembly, air-hose, power cord, etc.

post—An extension to the *yoke*'s tail that is inserted into the arm socket.

rate—The degree to which a link compensates for its vertical angle in order to maintain *iso-elasticity*; how rapidly the force required to move the arm up and down changes as the arm is moved up and down. As the rate is increased, *iso-elasticity* is decreased.

top-mounted—Refers to a method of mounting the *tool** on the arm so the tool is above the arm; with the tool mounted by inserting the post into the arm socket from the top.

underslung—Refers to a method of mounting the *tool** on the arm so the tool is below the arm; with the tool mounted by inserting the post into the arm socket from the bottom.

work—The point or area where the *tool** is applied or employed.

work envelope—The vertical and lateral ranges within which the *tool** contacts the *work*.

yoke—A U- or L-shaped bracket that allows the *tool** to rotate; it is the outermost part of the *gimbal-ing* mechanism. The *gimbal-post* assembly varies with the *tool** and work situation.

Getting started

In this chapter, you assemble the tools, material, and information you need to install the *zeroG*[®] arm, and do the analysis and make the decisions required for the setup.

Unpacking

1. Open the factory shipping carton and take out the bill of materials.
2. Ensure that you have the details of your *zeroG* arm's customization. These affect the installation of the gimbal-and-post assembly that holds the tool* and attaches it to the arm. They should be in either:
 - The original Equipois application summary that was provided with your proposal or any assembly drawings included with your system. Contact Equipois or your authorized representative if you are unable to find any documentation related to your specific customizations.
 - Or the packing list in the shipping box.
3. Inventory the contents of the shipping carton against the packing list.
4. If the contents do not match the packing list, report the discrepancy to Equipois.

Verify the mounting system

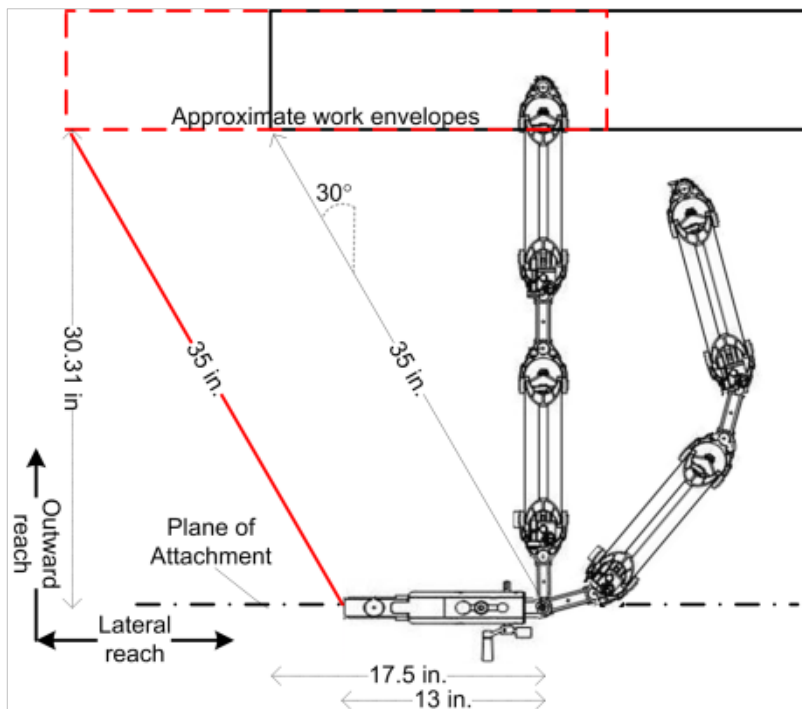

Figure 1 Outward and lateral reach

The mounting system must anchor the *zeroG* arm so the tool floats in the work envelope, which is the vertical and lateral range within which the tool contacts the work. If the work envelope requires the operator to move laterally beyond the reach of his arm, the mounting interface block can be placed on a moveable support, such as a sliding rail, crane arm, or cart. The mounting point, where the mounting interface block is attached to the mounting system, can be above or below the level of the work area.

**zeroG* arms can support things beside tools, such as parts and assemblies. For simplicity, "tool" in this document refers to whatever the customer mounts in the gimbal.

To ensure that the mounting system can position the mounting interface block so the tool naturally floats in the work envelope:

1. Measure the vertical reach of the post and gimbal (span A, Figure 2). _____
2. Note any additional vertical reach contributed by the tool during operation.

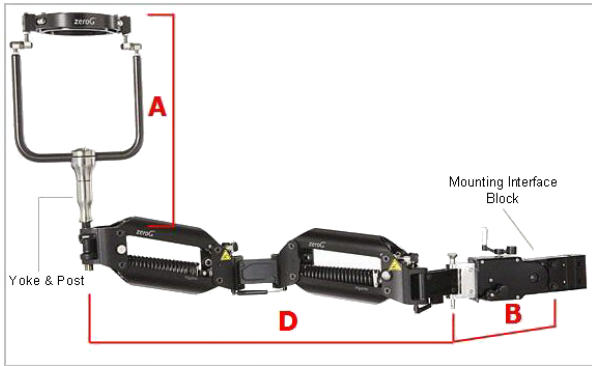

Figure 2 Spans A, B, and D

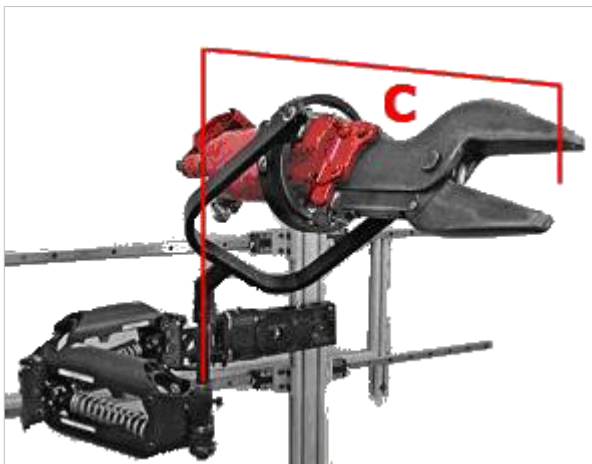

Figure 3 Span C

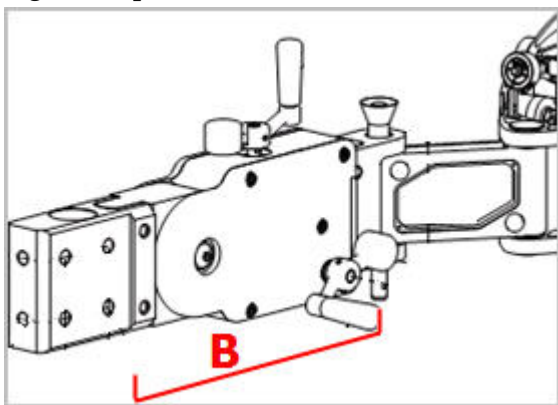

Figure 4 Span B

3. Add 1 and 2 for the total vertical reach. _____
4. Measure the distance from the mounting point to the work area perpendicular to the plane of attachment (see Figure 1). _____
5. Measure the horizontal offset from the mounting point provided by the mounting interface block and any other mounting apparatus (span B, Figure 2 and Figure 4). _____ As Figure 1 shows, this doesn't affect the outward reach much if it is less than 17 in., but a shorter offset can be significant if the work envelope is fairly wide, in which case you may need a moveable mounting system.
6. Note the horizontal reach of the tool, gimbal, and post assembly (span C, Figure 3). _____
7. Verify that the proposed mounting point satisfies these criteria:
 - The horizontal distance from the mounting point to the extremes of the work envelope is within the reach of the arm: 30 in.–35 in. arm (span D) + the horizontal reach of the tool, gimbal, and post (span C) + the horizontal offset of the mounting assembly (span B).
 - The vertical distance from the mounting point to the center of the work envelope is about the total vertical reach you noted above.
8. Inspect the mounting system to determine how the mounting interface block will be attached. There are three types of mounting interface blocks. As shown in Figure 5 on the next page, each is bored for:
 - A. Side mounting with 4 holes set in a square 1½ inches on a side, sized for 5/16 in.-18 bolts; this is preferred.
 - B. Post mounting on a 1⅝ inch post.
 - C. End mounting with holes set vertically 1½ inches apart, sized for 5/16 in.-18 bolts.

9. Make sure you have the tools and fasteners for attaching the mounting interface block to its support.
10. Have a $\frac{3}{32}$ -inch Allen wrench handy for adjusting the two-piece collar.
11. The arm is designed to bend slightly at the shoulder and elbow to accommodate the operator's arm—right-handed unless you ordered left-handed or no-handed.
 - a. Check the packing list to determine the handedness of the arm.
 - b. If you will be switching the arm's handedness from right to left or vice-versa, or removing the gas springs, go to the "Adjust the gas springs" section on page 16 to see what tools you will need. Some arms are not configured with gas springs.

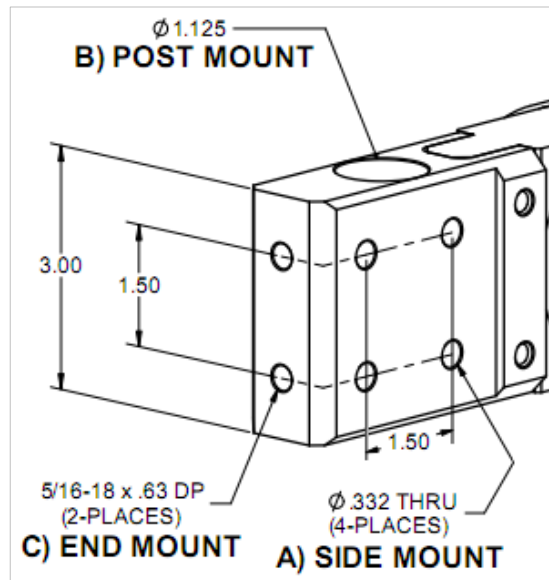



Figure 5 Mounting interface block borings

Attach the zeroG arm to the mounting system

Attaching the mounting interface block

In the previous section, you verified that your mounting system is ready.

1. Attach the mounting interface block to the support.

 Safety notes	
<p>The zeroG arm is made to flex effortlessly and follow you as you work, and it uses very strong springs to support the payload. Because the arm can move very fast and powerfully on its own, you must take care to keep it under control.</p>	
PINCH POINTS	<ul style="list-style-type: none"> • Keep fingers, clothing, tools, work pieces, and other items away from the labeled pinch points on the zeroG arm. • During operation, use the tool's grips and avoid touching the arm, except the adjustment cranks of the dynamic mounting interface block. • When the arm is not docked, handle it only by the end blocks and the adjustment knobs. • Use of protective covers is recommended.
DOCKING & POSITIONING	<p>Dock the zeroG arm in a horizontal position when it is not in active use. Do not leave the zeroG arm free or floating where it can easily swing or move.</p>
UNDOCKING AN UNLOADED ZEROG ARM	<p>An unloaded zeroG arm RISES FORCEFULLY and can injure users if it is released suddenly from its docked position. Never undock a zeroG arm unless the payload is loaded or the spring tension is balanced by restraints or a counter weight.</p>
PAYLOAD REMOVAL	<p>Mount or dismount the payload only if the zeroG arm is fully extended or is securely docked. Unless there is no alternative, do not use the built-in docking catch. See Docking on page 13.</p>

Attaching the arm to the mounting interface block

1. Before handling the arm, reread the safety notes above.
2. Read through this section.
3. Unpack the arm:
 - a. Remove the arm from the shipping case.
 - b. Loosen the wire restraint.
 - c. Lay one link on a table or the floor and hold it down.
 - d. Keeping a firm grip on the end block of the other link, unlatch the docking catch and carefully let the arm extend.
4. If necessary, reposition the gas springs, as described in the "Adjust the gas springs" section on page 16.
5. Mount the arm.
 - a. Avoiding pinch points and keeping your fingers and clothing from slipping inside the links, either:
 - Pick up the arm with your left hand
 - Or cradle the zeroG arm in your left arm
 - Or have an assistant help you hold the arm



- b. Align the sockets on the shoulder hinge block and the mounting interface block.
- c. Insert the clevis pin through the sockets.

Adjusting centering

The *zeroG* arm is designed to move almost effortlessly, so it is very sensitive to gravity. You can adjust the mounting interface block so the arm comes to rest centered or to the side only as far as you want it to. This is a preliminary rather than a precise or final adjustment. The adjustment will have to be refined when the payload is attached.

- Two of the three types of mounting interface blocks are adjustable. The static block is not adjustable.
- *Pitch* adjustment moves the bracket—where the arm attaches—up and down, in a head-nodding motion.
- *Roll* adjustment rotates the bracket, as viewed from the front.

The dynamic and preset mounting interface blocks have different adjustment mechanisms, but the process of adjustment is the same. Repeat these steps until the rest position is centered.

1. Hold the arm pointed toward the work area and without letting go completely, let it move freely.
2. If the arm drifts consistently to one side, adjust the pitch down and the roll away from the direction of drift.
3. If the arm drifts to either side, adjust the pitch down.

Adjust a dynamic mounting interface block

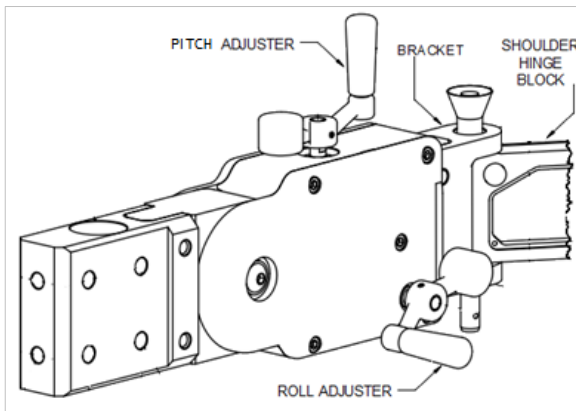

- Adjust roll by turning the crank on the side of the mounting interface block. Cranking clockwise rolls the bracket counterclockwise.
- Adjust pitch by turning the crank on the top of the mounting interface block. Cranking clockwise pitches the bracket down.

Adjust a preset mounting interface block

Adjustments are made with pairs of set screws.

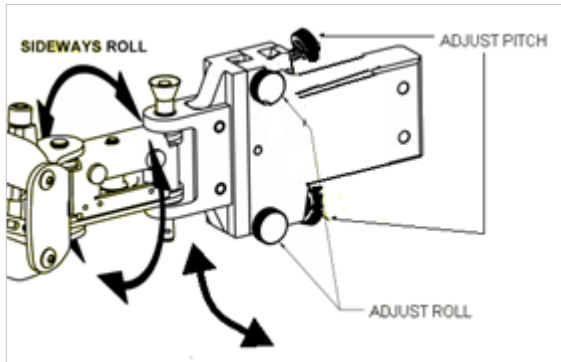

- Adjust roll with the knobs on the side. Back off one screw to create slack in the direction you want to move the block and tighten the other screw to move the bracket.
- Adjust pitch with the knobs on the back. You can unload the bottom screw by lifting the arm. Back off one screw to create slack in the direction you want to move the block and tighten the other screw to move the bracket.

When you are done, make sure both screws in each pair are tightened snugly.

Mounting the payload

Before you begin:

- You need a $\frac{3}{16}$ -inch Allen wrench for adjusting the two-piece collar.
- If you are mounting the payload on an extended arm, you may need an assistant, especially if it is an underslung mount.

1. Attach the tool to the gimbal.

The instructions for mating the tool and the gimbal are specific to the tool and gimbal and are in the packing list, the application summary, or the assembly drawing for your system.

2. Extend the arm or dock it securely. Do not mount the payload when you are using the built-in dock, unless there is no alternative.
3. Mount the payload—the tool-gimbal-post assembly—on the arm:
 - a. Loosen the two-piece collar with the Allen wrench.
 - b. If this is a top-mount, position the collar for the desired height and tighten it.
 - c. If this is an underslung mount, remove the collar.
 - d. Insert the gimbal post into the socket at the end of the arm.
 - e. If this is an underslung mount, have an assistant help you position and tighten the collar.

4. Attach cables and hoses, and tie them off with zip ties at the gimbal post and the elbow hinge.

5. Repeat the drift test and make adjustments as in step 1 above.

Note: With the tool mounted and the arm undocked, you can unload the adjustment mechanism by moving the tool to one side or the other or behind the mounting interface block. This is particularly applicable to the preset block. The dynamic block is designed to be adjustable with the payload in its working position.

6. Read the next section on docking and continue with the steps in “Adjusting the lift” and “Adjusting the rate”.

Docking



Figure 6 Docked zeroG arm

Note: zeroG arms can be fitted with other docking devices, such as a hook dock or a snap-in fitting. Consult your packing list or Equipois representative for more information.



MOUNT AND DISMOUNT THE PAYLOAD EITHER WITH THE ARM EXTENDED AND UNDER MINIMAL TENSION OR WHEN YOU ARE USING A SECURE DOCK, SUCH AS THE HOOK OR SNAP-IN FITTING. IF YOU **MUST** LOAD OR UNLOAD THE PAYLOAD USING THE MAGNETIC DOCK, BE VERY CAREFUL NOT TO DISLODGE THE CATCH.

LIKewise, EXTEND THE ARM WHEN YOU ATTACH IT TO AND DETACH IT FROM THE MOUNTING SYSTEM UNLESS THERE IS NO ALTERNATIVE.

Docking locks the zeroG arm and payload safely in an out-of-the-way position, as shown in Figure 6. The built-in magnetic catch is a convenient way to put the payload aside and easily pick it up again. However, this dock is not secure for mounting and dismounting the arm or payload, because it can easily be nudged loose, allowing the arm to extend suddenly.

To dock the arm with the built-in magnetic catch:

1. Swing the forearm back until it is slightly below and touching the upper arm.
2. Allow the magnets to grip.
3. Let the payload lift up until the stud on the forearm slips into the catch on the upper arm.

Adjusting the lift

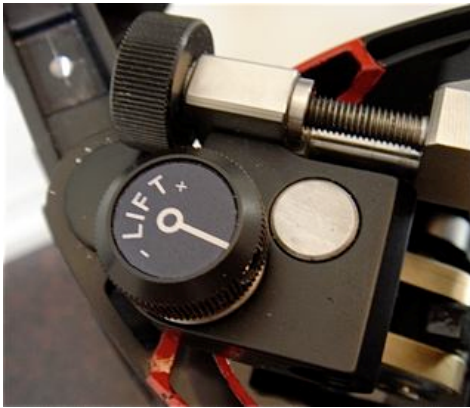

Figure 7 Lift adjusting knob and the Rate knob behind it



Figure 8 Link in position to adjust lift

Lift is the force that the links of the arm exert to resist the pull of gravity on the tool. The goal in this section is to adjust the lift so the tool floats in the work area with the links almost level. Some operators prefer to set the links at a higher angle, to help with a high average working height, or to assist in keeping the tool engaged with the work, for example, to push a drive-tool upward on a nut or to press a grinder against a surface.



- The distal link is the forearm, the link that holds the tool.
 - The proximal link is the upper arm. It can be a static link, which provides horizontal reach but cannot be swung up and down, and which is not adjustable.
1. With the payload in place, extend the arm.
 2. Move the payload so that the spring of the distal link is perpendicular to the adjusting mechanism. The link should be slanting at about 5° above level and the Lift knob should turn easily. See Figure 7 and Figure 8.
 3. Turn the Lift knob until the link balances at the 5° slant:
 - a. Turn the knob clockwise to *increase* lift, if you lifted the payload.
 - b. Turn the knob counterclockwise to *decrease* lift, if you pulled the payload down.
 4. In the same way, adjust the proximal link so it balances at the 5° slant.
 5. When the links are adjusted, carefully move the tool up and down to the full extent of its range. The links should track smoothly as you move the tool up and down. As you perform this step, a link may lock in the full up or down position. This can happen when the link is adjusted for a heavy payload. You address this problem in the next section
 6. Hold the arm pointed toward the work area and without letting go completely, let it move freely. Repeat these adjustments until the arm's rest position is where you want it.
 - a. If the arm drifts consistently to one side, move the resting position toward the center by adjusting the pitch down and the roll away from the direction of drift.

- b. If the arm drifts to either side, adjust the pitch down.

Adjusting the rate

As the tool moves up and down, the links maintain iso-elasticity by compensating for changes in their angles. The degree of compensation is called rate. The arm is shipped from the factory with the Rate knobs turned fully counterclockwise for maximum iso-elasticity. This setting is preferred by most operators and is recommended for most applications. (See the glossary on page 4 for explanations of *rate* and *iso-elasticity*.)

When lift is increased for a heavier payload, a link may lock in an up or down position at the extremes of vertical motion, requiring reduced iso-elasticity.

To adjust the rate:

1. Raise the link to the full up position.
2. To decrease iso-elasticity and make it harder for the operator or the arm to raise or lower the tool, turn the Rate knob clockwise.
3. To increase iso-elasticity and make it easier to move the tool through the full range of vertical motion, turn the Rate knob counterclockwise.
4. When the link no longer locks up, adjust the lift so the arm floats in the proper attitude.

Installing accessories

1. Install optional accessories, such as custom docking systems and protective covers. These are shipped with their own installation instructions.

Note: Most arms are shipped with disposable covers. Covers protect the arm from dirt and shield pinch points, but they also keep operators from easily adjusting the arm's settings. Contact Equipois for more information about covers.

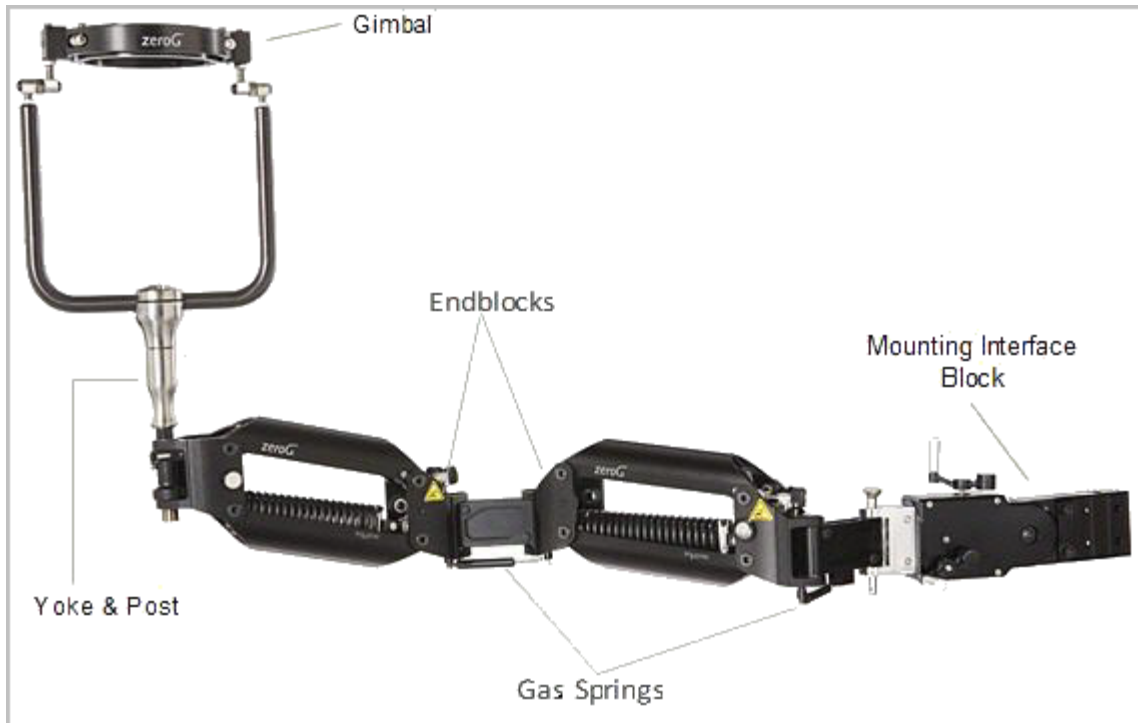

Figure 9 zeroG arm in right-hand orientation

Adjust the gas springs

The gas springs help the zeroG arm return to a home position when the tool is released and to hold a slightly bent orientation, adapted to either a left- or right-handed operator. They also cause the arm always to fold in the same direction, with the elbow moving away from the operator. This function is optional, and the arm can be operated without the gas springs.

The gas springs are on the bottom of the arm and attach to the end blocks of the links, as shown in Figure 9.

Use the instructions in this section for three tasks:

- Changing the arm between a right- and left-handed orientation. You can reuse all the parts, or you can install new parts from one of the two conversion kits.
- Switching between a long (the standard) and short shoulder mount. This can be done by itself or while changing the handedness. Changing the length of the shoulder mount requires a conversion kit with the new shoulder mount:
 - 101-6250-04: Kit, Gas Spring, RH to LH Conversion, Long Shoulder
 - 101-6250-03: Kit, Gas Spring, RH to LH Conversion, Short Shoulder
- Removing the gas springs.

Removing the gas springs



WARNING: DO NOT WORK ON A FOLDED ARM.

1. Assemble these tools:
 - 6-inch C-clamp
 - $\frac{3}{32}$ -inch Allen wrench
 - $\frac{3}{8}$ -inch open-end or crescent wrench
 - Flat work surface
 - Mallet
2. If the arm has not been unpacked:
 - a. Check the packing list for the handedness and for a conversion kit.
 - b. Remove the arm from the shipping case.
 - c. Loosen the wire restraint.
 - d. Lay one link on a table or the floor and hold it down.
 - e. Keeping a firm grip on the end block of the other link, unlatch the docking catch and carefully let the arm extend.
3. If the arm has been installed, perform these steps, as necessary:
 - a. If it is possible to remove the payload with the arm extended, extend the arm.
 - b. Remove the payload.
 - c. With the arm extended, adjust the lift so the arm is approximately horizontal (see “



- Adjusting the lift" on page 14).
- d. Dismount the arm.
 - e. Lay the arm upside-down on the work bench.
4. The elbow gas spring is between the arm segments. Make a note of where the screw posts are inserted into the end blocks relative to the hinge pins.
 - When the arm is deployed, the screw posts are on the outside of the curve.
 5. With the C-clamp, squeeze the ends of the elbow gas spring (nearer the tool) to take tension off the screw posts.
 6. Remove the screws holding the gas spring in place:
 - a. With the Allen wrench, loosen one of the screws.
 - b. Note the placement of the washers.
 - c. Remove the screw.
 - d. Repeat for the other screw and remove the gas spring.
 7. With the open-end wrench, remove the screw posts.
 8. With the C-clamp, squeeze the ends of the shoulder gas spring (nearer the mounting interface block) enough to take tension off the screw posts.
 9. Remove the screws holding the gas spring in place:
 - a. With the Allen wrench, loosen one of the screws.
 - b. Note the placement of the washers.
 - c. Remove the screw.
 - d. Repeat for the other screw and remove the gas spring.
 10. With the open-end wrench, remove the screw post from the proximal link.
 11. With the Allen wrench, remove the screw holding the shoulder mount to the shoulder hinge block.
 12. Remove the shoulder mount from the hinge block. You may need a mallet.
 13. If you are reusing the parts in a handedness conversion:
 - a. Remove the screw (or wedge) post from the shoulder mount.
 - b. Align the threads of the screw post carefully, since they are easily cross-threaded and install it on the other side.
 - c. Or press the wedge post into the socket on the other side of the shoulder mount. You may need to use the C-clamp.



Installing the gas springs



WARNING

WORKING ON A FOLDED ARM IS NOT SAFE.

DO THE WORK ON AN EXTENDED ARM.

FIGURE 11 SHOWS THE ARM DISMOUNTED AND FOLDED. THIS IS ONLY FOR CONVENIENCE IN SHOWING THE PLACEMENT AND ORIENTATION OF GAS SPRINGS AND OTHER PARTS.

You can use parts you removed or parts from a conversion kit.

Note: The kits differ in having either a long or a short shoulder mount with a matching gas spring:

- If you are installing a long shoulder mount (part number 101-6220-01), both elbow and shoulder use a 1.5 x 20 lbs. gas spring (p/n 900-9016-GS).
- If you are installing a short shoulder mount (p/n 101-6220-02), the elbow uses a 1.5 x 20 lbs. gas spring (p/n 900-9016-GS) and the shoulder a uses 1.0 x 20 lbs. gas spring (p/n 900-9015-GS).

1. Assemble these tools and materials:

- 6-inch C-clamp
- $\frac{3}{32}$ -inch Allen wrench
- $\frac{3}{8}$ -inch open-end or crescent wrench
- Flat work surface
- Mallet
- Rag and isopropyl alcohol (IPA) or similar cleaning solvent
- Grease
- Removable thread glue, such as Loctite® Threadlocker Blue

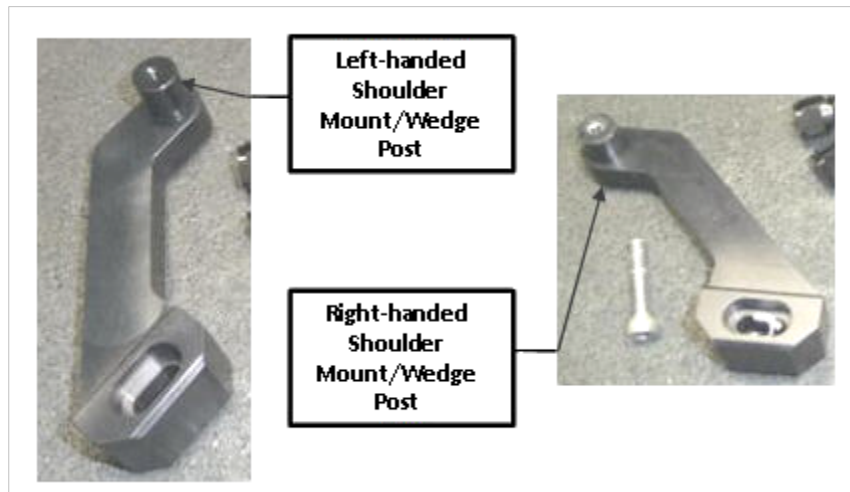

Figure 10 Left and right orientation of the wedge post in the shoulder block

2. Make sure the screw or wedge post is on the correct side of the shoulder mount, as shown in Figure 10.

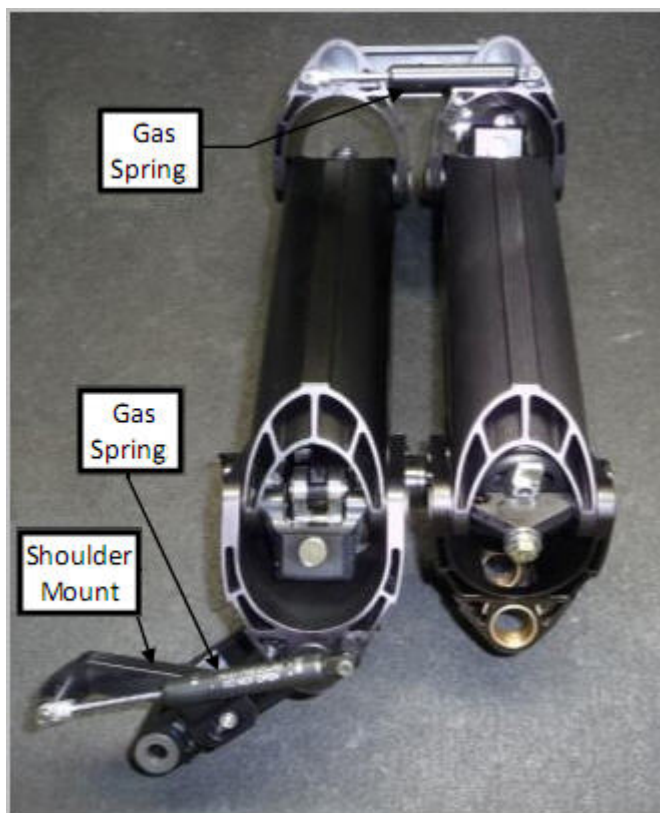

Figure 11 Folded arm, upside down, in right-hand orientation. Do not WORK on a folded arm.



3. Orient the positions of the parts for installing the shoulder gas spring. Use Figure 11, where the arm is shown upside down with the elbow pointed away from you, as a guide.
 - For right-handed orientation, the screw post goes to the right of the hinge pin and the shoulder mount extends toward the left.
 - For left-handed orientation, the screw post goes to the left of the hinge pin and the shoulder mount extends toward the right.
4. Attach the shoulder mount:
 - a. Press the shoulder mount into the bottom of the shoulder hinge block, using the C-clamp if necessary.
 - b. Use a mallet to center the shoulder mount in the slot.
 - c. Apply thread glue to the screw and tighten it firmly with the Allen wrench.
5. Insert the shoulder screw post:
 - a. Apply thread glue to the shoulder screw post.
 - b. IT IS EASY TO CROSSTHREAD THE SCREW POST.
Carefully align the threads in the socket in the shoulder end block, as indicated in step 3 above.
 - c. Use the open-end wrench to tighten the screw post.

6. Clean the screw posts (or screw and wedge posts) with a rag and solvent.
7. Install the shoulder gas spring, p/n 900-9015-GS for the short shoulder mount, p/n 900-9016-GS for the long shoulder mount:
 - a. Apply a dab of grease to the shoulder of each screw, between the threads and the head. DO NOT PUT GREASE ON THE THREADS.
 - b. Apply thread glue to the threads.
 - c. If necessary, compress the gas spring with the C-clamp.
 - d. Fasten the gas spring to the screw posts (or wedge post and screw post) and tighten the screws with the Allen wrench.
8. Orient the positions of the parts for installing the elbow gas spring. Use Figure 11, arm upside down with the elbow pointed away from you, as a guide.
 - For right-handed orientation, the screw posts go in the outside fittings of the end posts, that is, at the longer extension.
 - For left-handed orientation, the screw posts go in the inside fittings of the end blocks, that is, at the shorter extension.
9. Insert the elbow screw posts, :
 - a. Apply thread glue to the elbow screw posts.
 - b. IT IS EASY TO CROSSTHREAD THE SCREW POST.
Carefully align the threads in the sockets in the elbow end blocks, as indicated in step 8 above.
 - c. Use the open-end wrench to tighten the screw posts.
10. Clean the screw posts with a rag and solvent.
11. Install the elbow gas spring, p/n 900-9016-GS:
 - a. Apply a dab of grease to the shoulder of each screw, between the threads and the head. DO NOT PUT GREASE ON THE THREADS.
 - b. Apply thread glue to the threads.
 - c. If necessary, compress the gas spring with the C-clamp.
 - d. Fit the gas spring to the screw posts and tighten the screws with the Allen wrench.



Appendices

zeroG⁴ arm Maintenance and Upkeep

Customer Maintenance Items	Frequency	Parts or Maintenance Required
<p>Springs:</p> <ul style="list-style-type: none"> • Clean using clean dry compressed air after each use if possible. • DO NOT use alcohol, WD-40 or other chemical based solvents to clean the spring or any other parts • Check each spring for any dents, nicks or deformation. Make sure paint still covers entire spring – no metal <i>rust</i> showing. If there are any type of identifiable defects, CONTACT EQUIPOIS. • See ‘Payload Testing’ if degradation of performance is noted. 	Monthly	<ul style="list-style-type: none"> • Replace complete link via link exchange program if needed*
<p>Adjuster Mechanism (internal to each link):</p> <ul style="list-style-type: none"> • Clean using clean dry compressed air after each use if possible. • Make sure that mechanism is able to travel the full length of the screw. 	Monthly	
<p>End Block:</p> <ul style="list-style-type: none"> • Is the Delrin sleeve in place? Are there any cracks or deformation? If so, replace as needed. 	Monthly	<ul style="list-style-type: none"> • Kit, Tool Interface Sleeve with Clip P/N 102-6281*
<p>Covers:</p> <ul style="list-style-type: none"> • Check to make sure cover has no tears or rips and is securely fastened to the arm. Replace as needed. 	Monthly	<ul style="list-style-type: none"> • Polyco Disposable Cover P/N 300-2100* • Silicone permanent cover P/N 300-2200*
<p>Docking:</p> <ul style="list-style-type: none"> • Each zeroG4 arm has magnetic docks that can be used for stowing the arm when not in use. Please clean using clean dry compressed air after each use if possible. • Equipois strongly recommends the use of additional ‘hook’ docks or other mechanisms to secure the arm in lieu of magnetic docks especially if covers are in use. 	Monthly	

<p>Arm Extrusions:</p> <ul style="list-style-type: none"> • Adjust lift knobs to zero load • Does arm function normally with no lift – are there any hitches or rough spots in the movement? • Does each arm segment move up and down freely without binding? If not, contact Equipois. 	<p>Quarterly or Semi-Annually</p>	<ul style="list-style-type: none"> • Apply grease to adjuster – Use Extreme Pressure Grease – P/N 900-7005-GR*
<p>Lift knob inspection:</p> <ul style="list-style-type: none"> • Does carrier work on linear shaft? • Clean shaft thoroughly • Re-grease shaft 	<p>Quarterly or Semi-Annually</p>	<ul style="list-style-type: none"> • Apply grease to adjuster – Use Extreme Pressure Grease – P/N 900-7005-GR*
<p>Rate knob inspection:</p> <ul style="list-style-type: none"> • Is it able to thread in and out without any issues? • Is there any looseness or wiggling detectable? If so, contact Equipois. 	<p>Quarterly or Semi-Annually</p>	
<p>Shoulder and Elbow Hinges:</p> <ul style="list-style-type: none"> • Hinges between links should be able to fully rotate on each bearing • Look for any play between where each hinge and block surface mates with the other • Are caps still on each elbow hinge bearing location? If not, is retaining clip visible or missing? • On elbow hinge, check to make sure washers are in place. If not, replace as needed. • Inspect to make sure bumper pads on sides of each hinge are in place. If not, replace. 	<p>Quarterly or Semi-Annually</p>	<ul style="list-style-type: none"> • Parts are included in Kit, Complete Maintenance Pack, zeroG4 – P/N 101-5910*
<p>Internal Bumpers (four per link):</p> <ul style="list-style-type: none"> • Check the connection. Are they loose in any way? Tighten and add Loctite if loose. • If bumpers connected to magnetic docks are loose, contact Equipois. 	<p>Quarterly or Semi-Annually</p>	<ul style="list-style-type: none"> • Contact Equipois for details for magnetic dock replacement.
<p>Gas Springs (at shoulder and elbow):</p> <p>Check to see if gas spring at each location is still providing force</p> <ul style="list-style-type: none"> • If not, replace with appropriate gas spring replacement kit. • Check screws at each gas hinge to make sure they are secure. If not securely fastened, use Blue Loctite 243 to secure. 	<p>Quarterly or Semi-Annual</p>	<ul style="list-style-type: none"> • All arms after S.N. 1029 utilize long shoulder kit. • Gas Spring Replacement Kit, Long Shoulder – P/N 101-6250-02* • Arms previous to S.N. 1029 utilize short shoulder kit. – P/N 101-6250-01 • Blue Loctite 243 – P/N 900-7001-TL*

<p>Labels and Indications:</p> <ul style="list-style-type: none"> • Are any labels peeling or torn off. Replace as needed. • Check for pinch point labels and stickers for Lift and Rate knobs. 	<p>Quarterly or Semi-Annual</p>	<ul style="list-style-type: none"> • Contact Equipois for safety label replacements.
<p>Perform payload testing:</p> <ul style="list-style-type: none"> • Run rate screw to full extension (threads all the way out), then run it back two full rotations. • Set-up testing post set-up and apply 30 lbs of weight – utilize barbells or whatever form of weights are available to get an accurate payload test. • Looks that arm can still lift payload with about 2-5 lbs of play +/-. • If there any concerns about spring payload performance, please contact Equipois. 	<p>Annual</p>	<ul style="list-style-type: none"> • Contact Equipois for Payload Test Post Kit

Interface Mounting Blocks

Customer Maintenance Items	Frequency	Parts or Maintenance Required
<p>Overall mounting block:</p> <ul style="list-style-type: none"> • Clean using clean dry compressed air after each use if possible, especially near exposed bearings on dynamic and pre-set mounts • DO NOT use alcohol, WD-40 or other chemical based solvents to clean any components or parts. 	<p>Monthly</p>	
<p>Connection to existing structure:</p> <ul style="list-style-type: none"> • Check to make sure that all bolts are secure and properly tightened. • Look to make sure that mounting block connection is still level and shows no signs of deformation. 	<p>Monthly</p>	<ul style="list-style-type: none"> • Kit, Replacement 80/20 Bolts & Nuts – P/N 500-4164*
<p>Arm Connection to mounting block:</p> <ul style="list-style-type: none"> • Is hinge able to slide in securely to female location on mounting block? • Check to make sure there are no gaps or wiggle between the male hinge and the female location on mounting block. • Make sure quick release pin can slide in and out of block and hinge. • Check to make sure KP bearings (or bushings if positioning arm) are seated correctly. 	<p>Quarterly or Semi-Annual</p>	<ul style="list-style-type: none"> • Quick Release Pin P/N 900-9031-QP* • Kit, Spare Bearings (Fully Dynamic Style) P/N 500-4265* • Kit, Spare Bearings (Positioning Style) P/N 500-4266*

<ul style="list-style-type: none"> • Replace KP bearings (or bushings) if needed. Consult Equipois for instructions on replacement. 		
<p>Leveling knobs or handles:</p> <ul style="list-style-type: none"> • Make sure all knobs (Pre-Set) or adjustment handles (Dynamic) are present and securely fastened. • For Pre-Set mount, check that each striker plate (stop plate for each screw) is in place. Striker plates can be found on the inside surface of each block. Replace as needed. • Check that adjustment handles have clearance to turn freely. If not, it may be necessary to reset their location. Allow for approximately 0.132 inches from surface to handle minimum. 	<p>Quarterly or Semi-Annual</p>	<p>Pre-Set 2-Axis:</p> <ul style="list-style-type: none"> • Pre-Set Knob Kit P/N 500-4262* <p>Dynamic 2-Axis:</p> <ul style="list-style-type: none"> • Adjustment Handle Kit P/N 500-4162*

S1 Ring Gimbals

Customer Maintenance Items	Frequency	Parts or Maintenance Required
<p>Overall S1 Ring Gimbal:</p> <ul style="list-style-type: none"> • Clean using clean dry compressed air after each use if possible, especially near exposed bearings on dynamic and pre-set mounts • <u>DO NOT</u> use alcohol, WD-40 or other chemical based solvents to clean any components or parts 	<p>Monthly</p>	
<p>Outer race of ring gimbal:</p> <ul style="list-style-type: none"> • Check to make sure that bearings rotate freely • Check to make sure that outer ring halves are properly seated and retaining screws are secure. • Quick Release Gimbal ONLY: <ul style="list-style-type: none"> ○ Locking side should have no play (snug fit) ○ Latch should shut completely. If latch does not seat, it is possible to adjust catch plate position. 	<p>Quarterly or Semi-Annual</p>	
<p>Inner race of ring gimbal:</p> <ul style="list-style-type: none"> • Check to make sure that inner ring halves are properly seated and retaining screws are secure. • Check to make sure that tool mounting set screws are each making contact and firmly seated against tool surface. • Set screws should be just flush with outside of gimbal surface after being tightened. If set 	<p>Quarterly or Semi-Annual</p>	<ul style="list-style-type: none"> • Kit, Retaining Screw, Inner Race, S1 P/N 400-3576* • Kit, Set screws, Assorted Lengths P/N 400-3575-01*

screw protrudes a different size set screw should be used.		
<p>Pivot Bearings at Yoke Connection (Double Yoke only):</p> <ul style="list-style-type: none"> • Make sure that ring can freely rotate in yoke without restriction. Replace bearings as needed. • Check jam nuts are seated and secure. If not, tighten and add Blue Loctite 	Quarterly or Semi-Annual	<ul style="list-style-type: none"> • Kit, Yoke Pivot P/N 400-3120-02* • Blue Loctite P/N 900-7001-TL*
<p>Wrist Bearing at Yoke Connection (Single Yoke only):</p> <ul style="list-style-type: none"> • Check inset bolt is tight – not to exceed 20 ft-lbs • Check that screws holding 	Quarterly or Semi-Annual	<ul style="list-style-type: none"> • Pivot, yoke to wrist P/N 400-3630
<p>Yoke Clamp:</p> <ul style="list-style-type: none"> • Make sure yoke clamp is tight around yoke. Check screws are tight and secure – tighten to 20 foot-lbs 	Quarterly or Semi-Annual	
<p>Gimbal Posts:</p> <ul style="list-style-type: none"> • Check to make sure no threads are visible between posts. If necessary, tighten to remove any gaps • There should be clamp collars on both the top and bottom of where the gimbal post attaches to the zeroG arm. A Teflon washer should <u>rest</u> underneath the top collar. • Each clamp collar should be firmly seated with screws tightened to 10 foot-lbs 	Quarterly or Semi-Annual	<ul style="list-style-type: none"> • Two-piece Clamp Collar Kit P/N 400-1112*

S2 Ring Gimbals

Customer Maintenance Items	Frequency	Parts or Maintenance Required
<p>Overall S2 Ring Gimbal:</p> <ul style="list-style-type: none"> • Clean using clean dry compressed air after each use if possible, especially near exposed bearings on dynamic and pre-set mounts. • <u>DO NOT</u> use alcohol, WD-40 or other chemical based solvents to clean any components or parts. 	Monthly	
<p>Rollers or Slides:</p> <ul style="list-style-type: none"> • Rollers or slides can be located on the inner or outer ring. Check to make sure that each ring rotates freely. • Rollers should be secured firmly via each 	Quarterly or Semi-Annual	<ul style="list-style-type: none"> • S2 Roller Kit P/N 400-3610-15* • S2 Slide Kit P/N 400-3612-11* • Kit, Set screws, Assorted

<p>screw. Screws should be tightened to 20 inch-lbs and Blue Loctite applied.</p> <ul style="list-style-type: none"> • If slides are used, position for a controlled roll of opposing ring by adjusting to desired resistance (inner/outer). • Tighten screws on each slide to 10-12 inch-lbs. 		<p>Lengths P/N 400-3575-01*</p> <ul style="list-style-type: none"> • Blue Loctite P/N 900-7001-TL*
<p>Pivot Bearings at Yoke Connection (Double Yoke only):</p> <ul style="list-style-type: none"> • Make sure that ring can freely rotate in yoke without restriction. Replace bearings as needed. • Check jam nuts are seated and secure. If not, tighten and add Blue Loctite 	Quarterly or Semi-Annual	<ul style="list-style-type: none"> • Axle Pivot Bearing P/N 900-9032-BG* • Blue Loctite P/N 900-7001-TL*
<p>Wrist Bearing at Yoke Connection (Single Yoke only):</p> <ul style="list-style-type: none"> • Check that inset bolt is <i>tight</i> – not to exceed 20 ft-lbs • Check that screws are secure and tight 	Quarterly or Semi-Annual	<ul style="list-style-type: none"> • Pivot, yoke to wrist P/N 400-3630
<p>Yoke Clamp:</p> <ul style="list-style-type: none"> • Make sure yoke clamp is tight around yoke. Check that screws are <i>tight and secure</i> – tighten to 20 foot-lbs 	Quarterly or Semi-Annual	
<p>Gimbal Posts:</p> <ul style="list-style-type: none"> • Check to make sure no threads are visible between posts. If necessary, tighten to remove any gaps • There should be clamp collars on both the top and bottom of where the gimbal post attaches to the zeroG arm. A Teflon washer should <i>rest</i> underneath the top collar. • Each clamp collar should be firmly seated with screws tightened to 10 foot-lbs 	Quarterly or Semi-Annual	<ul style="list-style-type: none"> • Two-piece Clamp Collar Kit P/N 400-1112*

Palm Sander Gimbal

Customer Maintenance Items	Frequency	Parts or Maintenance Required
<p>Overall Gimbal:</p> <ul style="list-style-type: none"> • Clean using clean dry compressed air after each use if possible, especially near exposed bearings on dynamic and pre-set mounts • <i>DO NOT</i> use alcohol, WD-40 or other chemical based solvents to clean any components or parts 	Monthly	
Gimbal Posts:	Quarterly or Semi-	<ul style="list-style-type: none"> • Two-piece Clamp Collar Kit

<ul style="list-style-type: none"> • Check to make sure no threads are visible between posts. If necessary, tighten to remove any gaps • There should be clamp collars on both the top and bottom of where the gimbal post attaches to the zeroG arm. A Teflon washer should be underneath the top collar. • Each clamp collar should be firmly seated with screws tightened to 10 foot-lbs • Check jam nuts are seated and secure. If not, tighten and add Blue Loctite • Check that counterweight set screw is secure. If not tighten and ad Blue Loctite 	<p>Annual</p>	<p>P/N 400-1112*</p> <ul style="list-style-type: none"> • Blue Loctite P/N 900-7001-TL*
--	---------------	--

RECOMMENDED SPARE PARTS

QTY	DESCRIPTION	PART NUMBER	PRICE
<u>zeroG4 Arm</u>			
1	Kit, Complete Maintenance Pack, zeroG4	101-5910	\$621.00
	<u>Included in Maintenance Kit:</u>		
1	Tool Interface Sleeve	102-6280	
1	Retainer Clip	900-9117	
4	Disposable, Polyco Arm Cover	300-2100	
1	Silicone Arm Cover	300-2200	
2	Extreme Pressure Grease	900-7005-GR	
1	O-Ring Grip Washer	101-6371	
1	Buna O-Ring 18mm	900-9105	
4	Bumper pads	900-9025-BP	
1	Kit, Gas Spring, Long Shoulder	101-6250-02	
2	Blue Loctite, 243, 10 mL	900-7001-TL	
<u>Available Separately:</u>			
1	Kit, Tool Interface Sleeve with Clip	102-6281	\$42.50
1	Disposable, Polyco Arm Cover	300-2100	\$26.50
1	Silicone Arm Cover	300-2200	\$250.00
1	Extreme Pressure Grease	900-7005-GR	\$24.00
1	Kit, Gas Spring, Long Shoulder	101-6250-02	\$165.00
<u>Fixed, Interface Mounting Block</u>			
1	Kit, Replacement 80/20 Bolts & Nuts	500-4164	\$12.50
1	Quick Release Pin	900-9031-QP	\$50.00

RECOMMENDED SPARE PARTS (Cont'd.)

QTY	DESCRIPTION	PART NUMBER	PRICE
<u>Pre-Set, 2-Axis, Interface Mounting Block</u>			
1	Kit, Complete Maint. Pack, Pre-Set Mount	500-4260	\$250.00
<u>Included in Maintenance Kit:</u>			
1	Kit, Replacement 80/20 Bolts & Nuts	500-4164	
1	Quick Release Pin	900-9031-QP	
1	Kit, Spare Brgs, Full Float Mtg Interface	500-4265	
1	Kit, Spare Brgs, Positioning, Mtg Intfc.	500-4266	
1	Kit, Replacement Knobs, Pre-Set Mount	500-5262	
<u>Available Separately:</u>			
1	Kit, Replacement 80/20 Bolts & Nuts	500-4164	\$12.50
1	Quick Release Pin	900-9031-QP	\$50.00
1	Kit, Replacement Knobs Pre-Set Mount	500-4262	\$68.00
<u>Dynamic, 2-Axis, Interface Mounting Block</u>			
1	Kit, Complete Maintenance Pack, Dynamic Mt.	500-4160	\$250.00
<u>Included in Maintenance Kit:</u>			
1	Kit, Replacement 80/20 Bolts & Nuts	500-4164	
1	Quick Release Pin	900-9031-QP	
1	Kit, Spare Brgs, Full Float Mtg Interface	500-4265	
1	Kit, Spare Brgs, Positioning, Mtg Intfc.	500-4266	
1	Kit, Replacement Knobs, Dynamic Mt.	500-4162	
<u>Available Separately:</u>			
1	Kit, Replacement 80/20 Bolts & Nuts	500-4164	\$12.50
2	Quick Release Pin	900-9031-QP	\$50.00
1	Kit, Replacement Knobs Dynamic Mount	500-4162	\$75.00
<u>S1 Ring Gimbal</u>			
1	Kit, Complete Maint. Pack, S1 Ring Gimbal	400-3574	\$265.00
<u>Included in Maintenance Kit:</u>			
1	Kit, Retaining Screw, Inner Race, S1	400-3576	
1	Kit, Set Screws, S1 Assorted Lengths	400-3575-01	
1	Kit, 2-Piece Collar & Washer (Qty 2)	400-1112	
2	Blue Loctite, 243, 10 mL	900-7001-TL	
<u>Available Separately:</u>			
1	Kit, Retaining Screw, Inner Race, S1	400-3576	\$4.50
1	Kit, Set Screws, Assorted Lengths	400-3575-01	\$30.50
1	Kit, 2-Piece Collar & Teflon Wash (Qty 2)	400-1112	\$26.50
2	Blue Loctite, 243, 10 mL	900-7001-TL	\$3.50
1	Kit, Yoke Pivot, Standard S1	400-3120-02	\$130.50

RECOMMENDED SPARE PARTS (Cont'd.)

QTY	DESCRIPTION	PART NUMBER	PRICE
<u>S2 Ring Gimbal</u>			
1	Kit, Complete Maint. Pack, S2 Ring Gimbal	400-3675	\$425.00
<u>Included in Maintenance Kit:</u>			
1	S2 Roller Kit (if gimbal employs rollers)	400-3610-15	
1	S2 Slide Kit (if gimbal employs slides)	400-3612-11	
1	Kit, Set Screws, Assorted Lengths	400-3575-01	
1	Kit, 2-Piece Collar & Washer (Qty 2)	400-1112	
2	Blue Loctite, 243, 10 mL	900-7001-TL	
<u>Available Separately:</u>			
1	S2 Roller Kit (if gimbal employs rollers vs slides)	400-3610-15	\$175.00
1	S2 Slide Kit (if gimbal employs slides vs rollers)	400-3612-11	\$220.00
1	Kit, Set Screws, Assorted Lengths	400-3575-01	\$30.50
2	Blue Loctite, 243, 10 mL	900-7001-TL	\$3.50
1	Kit, 2-Piece Collar & Teflon Wash (Qty 2)	400-1112	\$26.50
<u>Palm Sander Gimbal</u>			
1	Kit, Complete Maint. Pack, Sander Gimbal	400-3970	\$130.00
<u>Included in Maintenance Kit:</u>			
1	Kit, 2-Piece Collar & Washer (Qty 2)	400-1112	
2	Blue Loctite, 243, 10 mL	900-7001-TL	
3	Kit, Axle Pivot, MAG (Multi-Axis gimbal)	400-3430	
<u>Available Separately:</u>			
1	Kit, 2-Piece Collar & Teflon Wash (Qty 2)	400-1112	\$26.50
2	Blue Loctite, 243, 10 mL	900-7001-TL	\$3.50
3	Kit, Axle Pivot, MAG (Multi-Axis gimbal ONLY)	400-3430	\$33.00

zeroG⁴ arm technical specifications

PRIMARY WORK ENVELOPE	Vertical reach 32", horizontal reach 35", with 13.9" links, 3.6" hinge blocks, and 130° up/down sweep. Additional reach may be provided by the tool-gimbal-post assembly, static links, and the mounting interface block.
SECONDARY WORK ENVELOPE	Unlimited. Provided by auxiliary stands and mounts.
LIFT CAPACITY	Standard payload range is 8–36 lbs. The arm can be ordered configured for additional weight. Call Equipois for information.
PRIMARY ARM WEIGHT	Approx. 14 lbs; exclusive of the tool-gimbal-post assembly.
ORIENTATION CONTROL	Two optional gas springs provide right- or left-handedness and added arm stability.
MOUNTING INTERFACE BLOCKS	Three types compatible with OEM rail and strut systems. Two types provide 2-axis (pitch and roll) quick adjustments.

Safety and hazard review



WEIGHT CAPACITY	Payload capacity is 8–36 lbs. Do not load more than 36 lbs. on your zeroG arm unless it has been custom-fitted for the additional weight.
PINCH POINTS	<ul style="list-style-type: none"> • Keep fingers, clothing, tools, work pieces, and other items away from the labeled pinch points on the zeroG arm. • During operation, use the tool's grips and avoid touching the arm, except the adjustment cranks of the dynamic mounting interface block. • When the arm is not docked, handle it only by the end blocks and the adjustment knobs. • Use of protective covers is recommended.
ENVIRONMENTAL HAZARDS	Keep liquids, dust, paint, and debris away from the zeroG arm, or protect arm segments with disposable or permanent arm covers from Equipois.
DOCKING AND POSITIONING	Dock the zeroG arm when it is not in active use. Do not leave the zeroG arm free so it can easily swing or move.
PAYLOAD REMOVAL	Mount or dismount the payload only if the zeroG arm is fully extended or is securely docked. Unless there is no alternative, do not use the built-in docking catch. See Docking on page 13.
LEANING OR HANGING	Do not lean or hang from the zeroG arm.
UNDOCKING AN UNLOADED ZEROG ARM	An unloaded zeroG arm RISES FORCEFULLY and can injure users if it is suddenly released from its docked position. Never undock a zeroG arm unless it is loaded with its intended payload or the spring tension is balanced by restraints or a counter weight.
LIFT AND RATE ADJUSTMENTS	When adjusting the zeroG arm's lift or rate, do not force the stops at the end of knob travel.